



PRESHEETER, SHEETER AND ODYSSEY OVEN

SINCE 1950, CASA HERRERA HAS DELIVERED QUALITY EQUIPMENT TO THE SNACK FOOD & TORTILLA INDUSTRIES.

WE WILL CONTINUE TO IMPROVE THE "ENERGY EFFICIENCIES OF OUR OVENS, FRYERS (ODYSSEY DESIGN) AND SHEETERS. AS WELL AS INDUSTRIAL BAKING SYSTEMS FOR YOUR WHEAT AND CORN TORTILLA PRODUCTION, CHAPATI BREAD AND TORTILLA CHIPS OR START UP SYSTEMS FOR FULL SCALE MASS PRODUCTION.

PRESHEETER FEATURES

- Provides continuous sheet of masa to sheeter rollers
- Paddles gently feed masa to primary rollers
- Doctor blades with tension ensures product release.
- Primary Rollers with gap adjustments for varied thickness control
- Variable speed controls on paddles and primary sheeting rollers
- Built on Mobile caster for easy moving for cleaning or design for stationary position.
- Level sensor for control feeding to sheeter head.
- Designed for standard corn flour masa or special blend masa

305 A FRAME SHEETER HEAD FEATURES

- Heavy wall "A" frame design to reduce frame deflection
- Heavy Series Rollers to ensure product thickness
- Differential Speed Motor package (no rear wire required)
- Micro Bevel roller fine tune adjustment.

- Tongue & Groove Hopper inserts (patented) to minimize leakage at sheeter head
- Easy rear placement of cutter by single operator.
- Pneumatic tension for front wire
- Pneumatic tension for cutter and lift
- Auto Gap Control (optional)

ODYSSEY SERIES OVEN FEATURES

- Longitudinal burner design for maximum fuel efficiency (patented)
- Individual burner adjustment.
- Side Mounted combustion design for easy access to combustion controls
- Vertical & Horizontal pilot ignition system (minimum BTU's required)
- Mesh Infeed with tilting feature for easy wire change out and motorized speed control
- Large diameter Oven drums for minimum belt tension
- Belt support system design for minimum belt wear and flame utilization
- Air Transfer slide on top transfer belt
- Pull out slide Second to third belt (patented)
- Dual insulated hinge doors and hood
- External mounted combustion blower with housing
- Exhaust Management system



FOR MORE INFORMATION CALL 800.624.3916

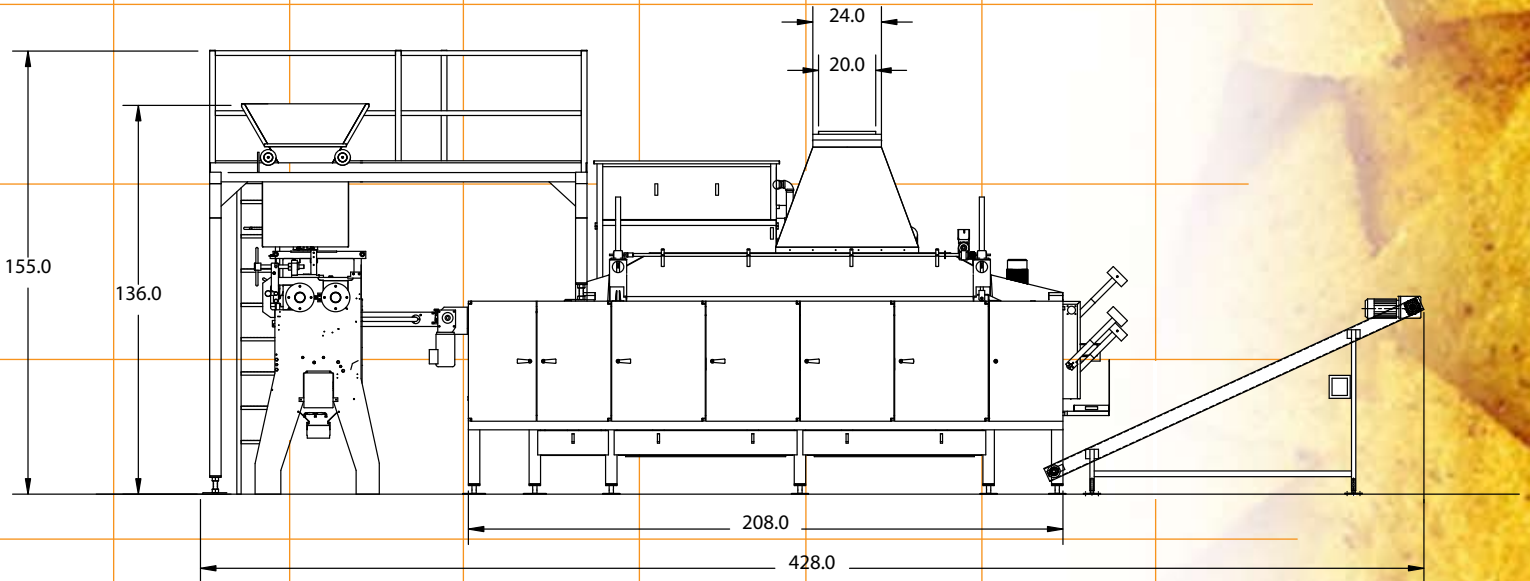
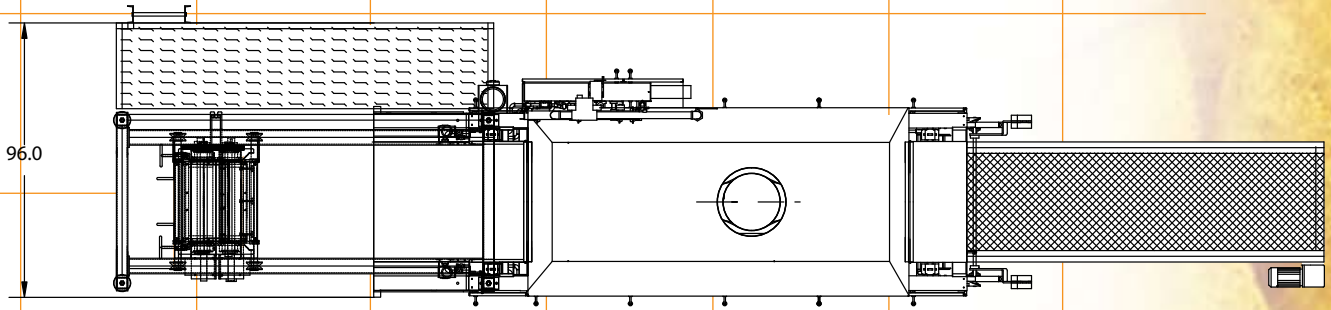

PRE-SHEETER
SHEETER
AND
ODYSSEY
OVEN



*We are constantly working
to develop and improve our
products to better serve
your growing needs.*



2655 NORTH PINE STREET, POMONA, CALIFORNIA 91767
TELEPHONE: 909.392.3930 FAX: 909.392.0231

WWW.CASAHERRERA.COM