

EQUILIBRATION CONVEYOR

A HIGHEST QUALITY EQUILIBRATION CONVEYOR ALLOWS BALANCE OF MOISTURE WITHIN THE PRODUCT BEFORE TRANSFERRING TO THE FRYING SYSTEM. THIS UNIT CAN BE CUSTOM ENGINEERED TO MEET INDIVIDUAL CUSTOMER SPECIFICATIONS WHICH INCLUDES SINGLE TIER, MULTIPLE TIER AND VARIOUS LENGTHS.

PRODUCT FEATURES

- *Rigid stainless steel tubular frame*
- *Designed for several types of belting, flat flex, open weave, chain driven or plastic belts*
- *Belt support rails design to ensure long belt life*
- *Heavy duty bearing and shafts*
- *Self-tensioning slide plates on bearing runners*
- *Adjustable product guide plates*
- *Safety interlock switches on main doors*
- *Optional types of motor gearbox drive packages*



FOR MORE INFORMATION CALL 800.624.3916

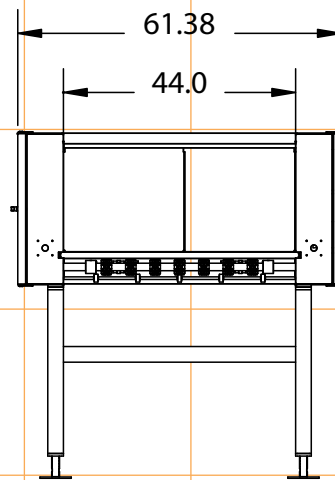
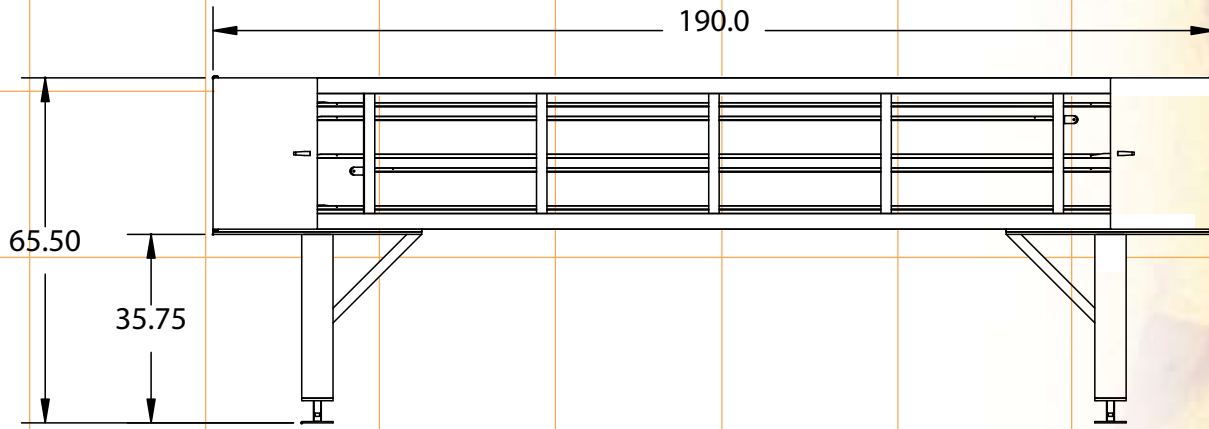

EQUILABRATION CONVEYOR



*We are constantly working
to develop and improve our
products to better serve
your growing needs.*



2655 NORTH PINE STREET, POMONA, CALIFORNIA 91767
TELEPHONE: 909.392.3930 FAX: 909.392.023

WWW.CASAHERRERA.COM